

THIS DOCUMENT CONTAINS DATA PROPRIETARY TO PROJECTS UNLIMITED, INC. ANY USE OR REPRODUCTION, IN ANY FORM, WITHOUT PRIOR WRITTEN PERMISSION OF PROJECTS UNLIMITED, INC. IS PROHIBITED.  
© 2005, Projects Unlimited Inc.

### SPECIFICATIONS

| PARAMETERS                  | VALUES          | UNITS |
|-----------------------------|-----------------|-------|
| RATED VOLTAGE (SQUARE WAVE) | 3.6             | Vpk   |
| OPERATING VOLTAGE RANGE     | 3 ~ 4.5         | Vpk   |
| RATED CURRENT (MAX)         | 100             | mA    |
| COIL RESISTANCE             | 18±5            | OHM   |
| MINIMUM SPL @ 10 CM         | 90              | dB    |
| RESONANT FREQUENCY          | 3,500±500       | Hz    |
| OPERATING TEMPERATURE       | -20 ~ +70       | °C    |
| STORAGE TEMPERATURE         | -40 ~ +85       | °C    |
| HOUSING MATERIAL            | LCP             | -     |
| TERMINAL MATERIAL           | Au PLATED BRASS | -     |
| WEIGHT                      | 0.8             | grams |

| REVISIONS |                           |        |          |
|-----------|---------------------------|--------|----------|
| LTR       | DESCRIPTION               | DATE   | APPROVED |
| -         | RELEASED FROM ENGINEERING | 3/8/16 |          |

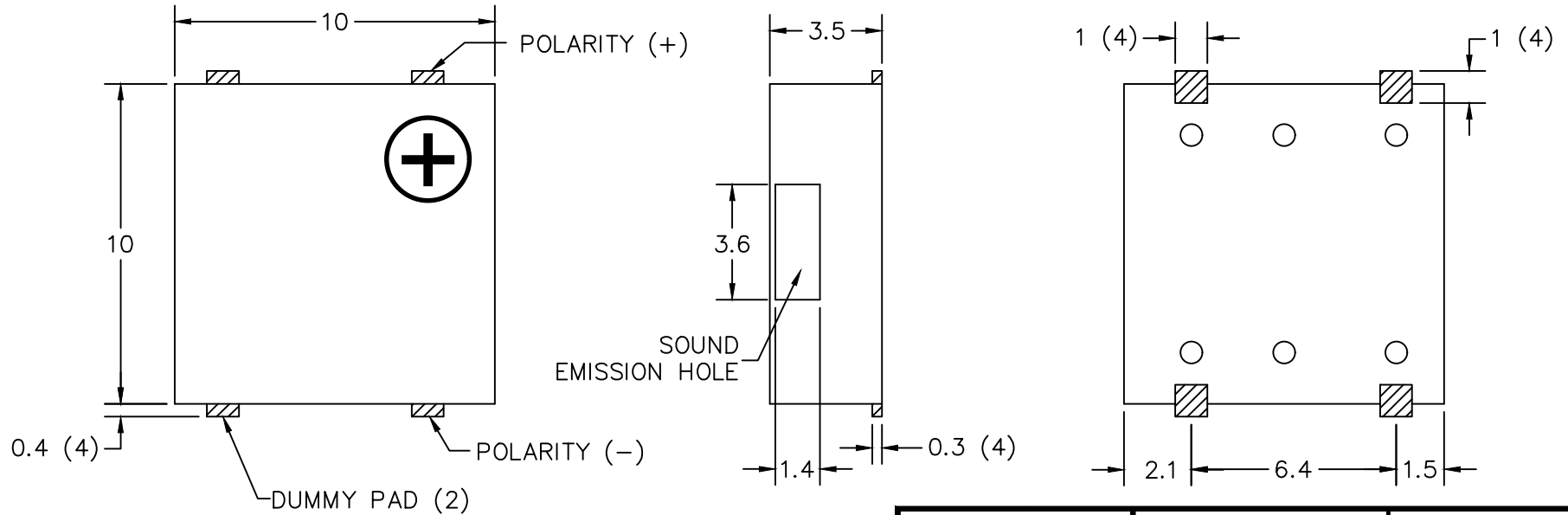

**NOTES:**

1. ALL DIMENSIONS ARE IN MILLIMETERS.
2. SPECIFICATION SUBJECT TO CHANGE OR WITHDRAWAL WITHOUT NOTICE.
3. THIS PART IS RoHS 2011/65/EU COMPLIANT.

FILE NAME  
SMT-1035-S-2-R.DWG

|   |      |  |   |
|---|------|--|---|
| UNLESS OTHERWISE SPECIFIED:<br>ALL PURCHASES ARE SUBJECT TO THE PUI AUDIO TERMS AND CONDITIONS SALE FOUND AT <a href="http://www.puiaudio.com/pdf/terms_conditions.pdf">http://www.puiaudio.com/pdf/terms_conditions.pdf</a> (paper copy available upon request).<br>DIMENSIONS ARE IN MILLIMETERS, TOLERANCES ARE ±0.5 AND ANGLES ARE ±3.° |      |  <p><b>pui audio</b> inc<br/>a projects unlimited company</p> | 3541 Stop Eight Road<br>Dayton, Ohio 45414                        |
| APPROVALS   | DATE |  |   |
| DRAWN   | M.L. | 3/16   | <b>TRANSDUCER (ELECTRO-MECH)</b><br>DRAWING NO.<br>SMT-1035-S-2-R |
| CHECKED   | M.L. | 3/16   |   |
| APPROVED  | B.R. | 3/16   |   |
| SIZE  |      | A  | SCALE: N.T.S.   |
|   |      |  | SHEET 1 of 1  |